

17-423/723: Designing Large-scale Software Systems

Design for Scalability

Mar 17 & 19, 2025

Learning Goals

- Describe scalability as a QA of a software system and its relationship with other QAs, such as performance, availability, and reliability.
- Specify a scalability QA in terms of load and performance metrics.
- Describe the differences between vertical and horizontal scaling.
- Describe the benefits and downsides of replication and partitioning approaches to distributed data.
- Describe different strategies for load balancing to avoid overloading parts of the system.
- Identify a bottleneck in the workload and apply caching to improve the system performance.

Scalability

What is Scalability?

- The ability of a system to handle growth in the amount of workload while maintaining an acceptable level of performance
- Why is scalability important?

Prime Big Deal Days

Included with a Prime membership

October 10-11



Internal documents show how Amazon scrambled to fix Prime Day glitches

PUBLISHED THU, JUL 19 2018•2:43 PM EDT | UPDATED THU, JUL 19 2018•6:16 PM EDT

- Amazon wasn't able to handle the traffic surge and failed to secure enough servers to meet the demand on Prime Day, according to expert review of internal documents obtained by CNBC.



Our servers are experiencing issues. Please come back later.



Failed to log in.

RETRY

TRY A DIFFERENT ACCOUNT

Pokémon Go makers call for calm as servers crash across Europe and US

Sat 16 Jul 2016 16.33 EDT



Travis (travtufts.bsky.social)

@travtufts · [Follow](#)



Using the Massachusetts vaccination website is like feverishly clicking on Ticketmaster with millions of other people, except instead of trying to see Beyoncé you're trying to keep parents alive in a pandemic.

[#mapoli](#)



This application crashed

If you are a visitor, please try again shortly.

If you are the owner of this application, check your logs for errors, or res

CORONAVIRUS

Massachusetts Vaccination Website Crash: What Went Wrong?

The state thinks the high volume of traffic may have been the cause, but they still aren't 100% certain

By **Staff and wire reports** • Published February 19, 2021 • Updated on February 19, 2021 at 9:01 pm



twitter

Twitter is over capacity.

Too many tweets! Please wait a moment and try again.

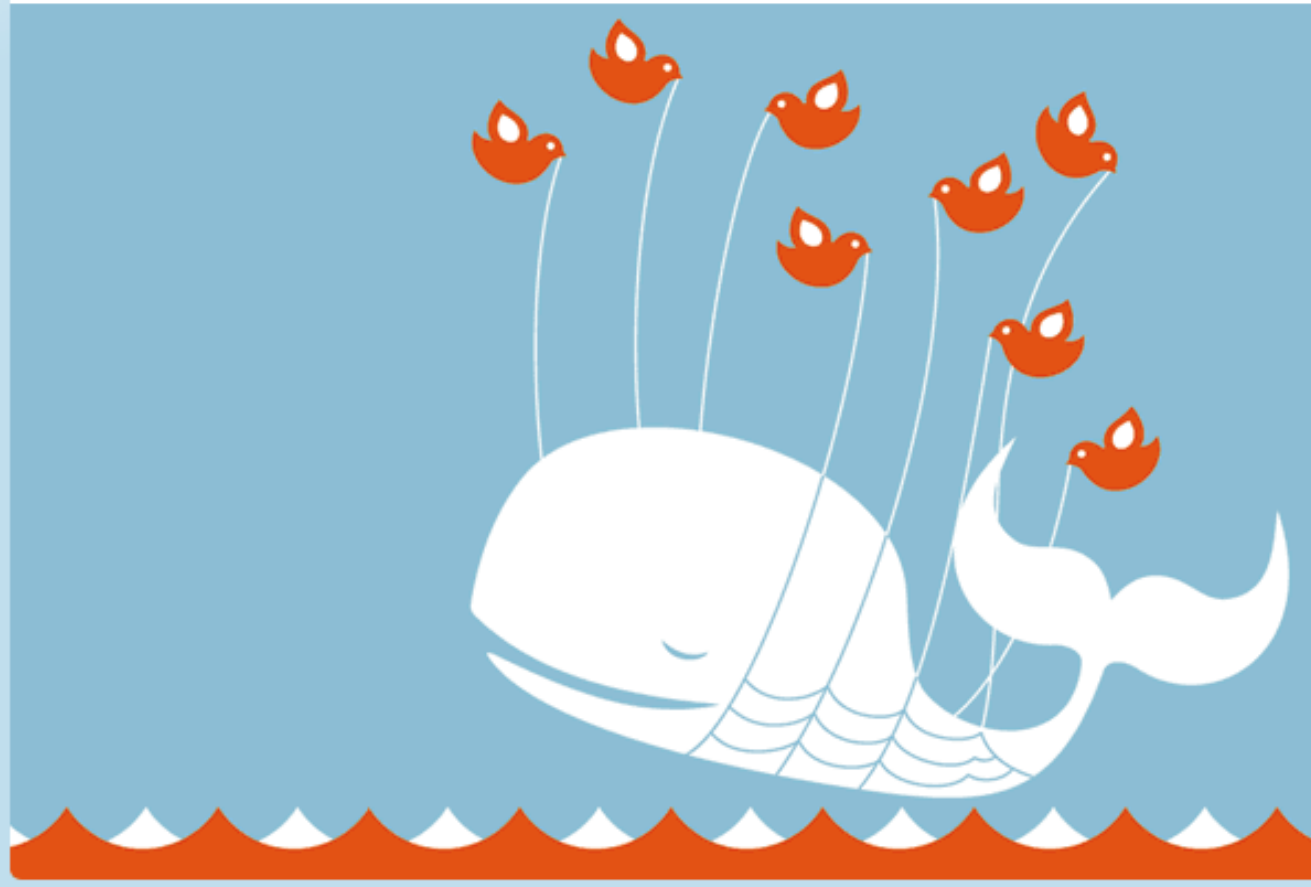

“Twitter fail whale”

Twitter Redesign for Scalability

- Early Twitter architecture (~2010): Monolithic design running Ruby on Rails, connected to MySQL databases
- Difficulty handling traffic spikes during major events (World Cup, Super Bowl, etc.,)
- Redesign decisions
 - Ruby -> JVM/Scala
 - Monolith -> Microservices
 - Load balancing, continuous monitoring, failover strategies
 - New, distributed database solution (Gizzard)

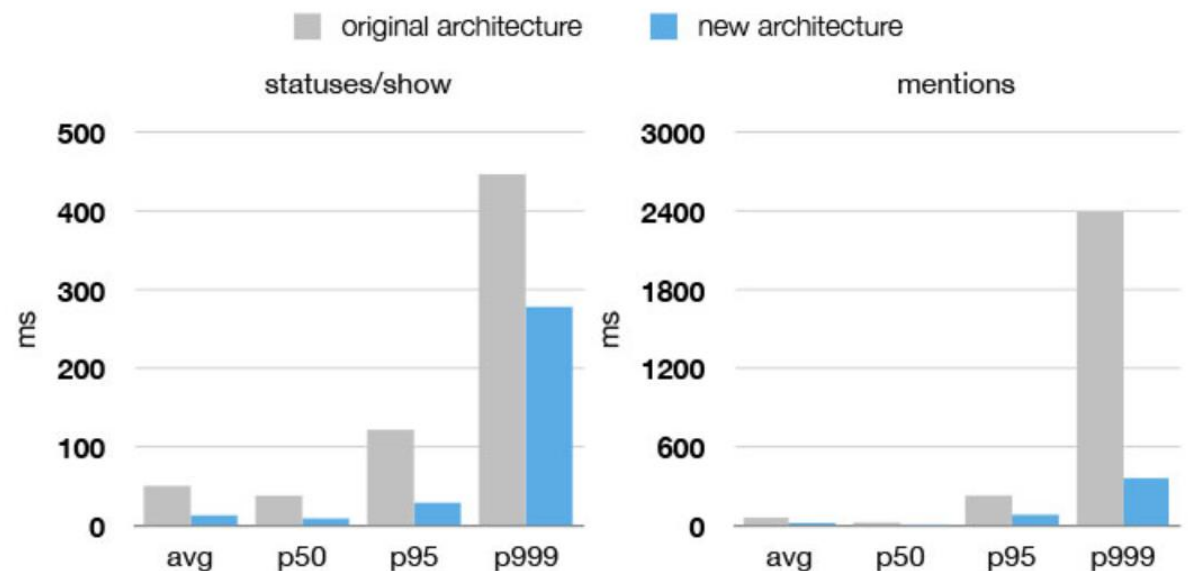

https://blog.twitter.com/engineering/en_us/a/2013/new-tweets-per-second-record-and-how

Related Concepts

- **Performance**: Amount of resources (e.g., time, memory, disk space) that the system consumes to perform a function
 - It's not just about time or responsiveness (but in this class, we will mostly talk about time-related attributes)
 - It's part of a scalability QA, but not the same!
- **Availability**: Degrees to which the system is available to perform its function(s) at the request of a client
 - Usually expressed in terms of probabilities (99.99% available)
- **Reliability**: Degrees to which the system performs its functions correctly
 - e.g., Mean time between failures (1000 hours before a sensor failure)
 - Availability does not imply reliability!

Specifying Scalability

- The ability of a system to handle growth in the amount of workload while maintaining an acceptable level of performance
- **Workload** (or simply, **load**): Amount of work that the system is given to perform
 - Number of client requests per second, average size of input data, number of concurrent users, etc.,
- **Performance**: Amount of resources that the system consumes to perform a function
 - Average response time, average throughput (i.e., number of requests successfully processed per hour), peak response time, CPU utilization, etc.,

Scalability Specification: Good & Bad Examples

- “Twitter must be able to handle 100 million additional users in the next year” ✘
- “The average time to load a tweet must be no more than 100 ms” ✘
- “Twitter must be able to handle 1 million concurrent requests for viewing tweets with an average response time of 100 ms” ✔
- “On Prime Day, the Amazon storefront should be 100% up and available” ✘
- “Netflix should be able to process addition of 1000 shows per day in its catalog with no more than 2% increase in average latency” ✔
- “The company should achieve active daily users of 10 million by the end of 2024” ✘

Load Parameters Example: Twitter

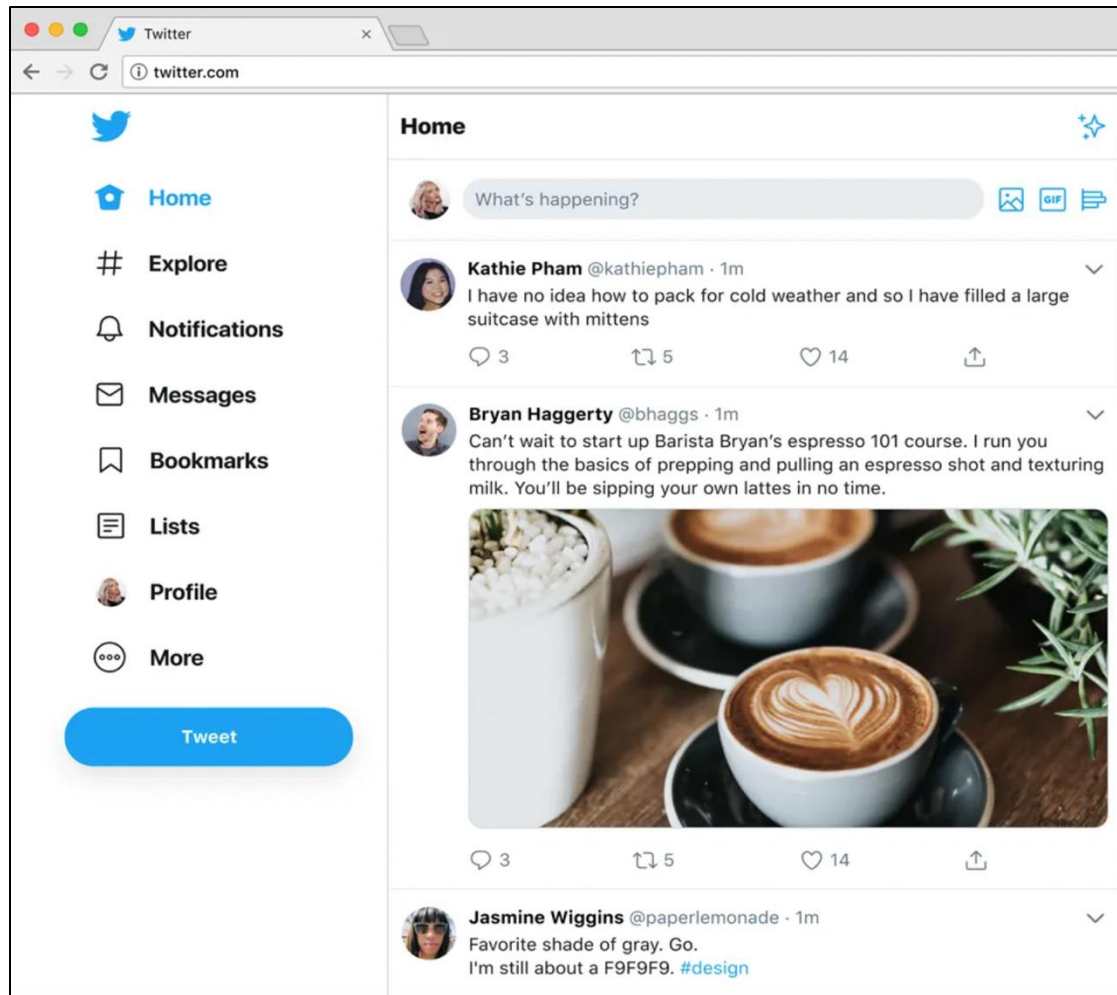

- **Post tweet:** Publish a tweet to followers
 - 4.6k requests/sec on average
 - 12k requests/sec at peak
- **View home timeline:** View tweets posted by the people that the user follows
 - 300k requests/sec on average
- **Fan-out problem:** Each user follows many people & each user is followed by many people
- **Q.** How would you design these two operations?

Example from: *Designing Data Intensive Applications*, Chapter 1, by M. Kleppmann

Design Option #1: Timeline Reconstruction

- **Post tweet:** Insert the new tweet into a global database of tweets.
- **View timeline:** Reconstruct the timeline for each request - (1) look up all the people the user follows, (2) find all the tweets for each of these people, (3) merge & sort by time

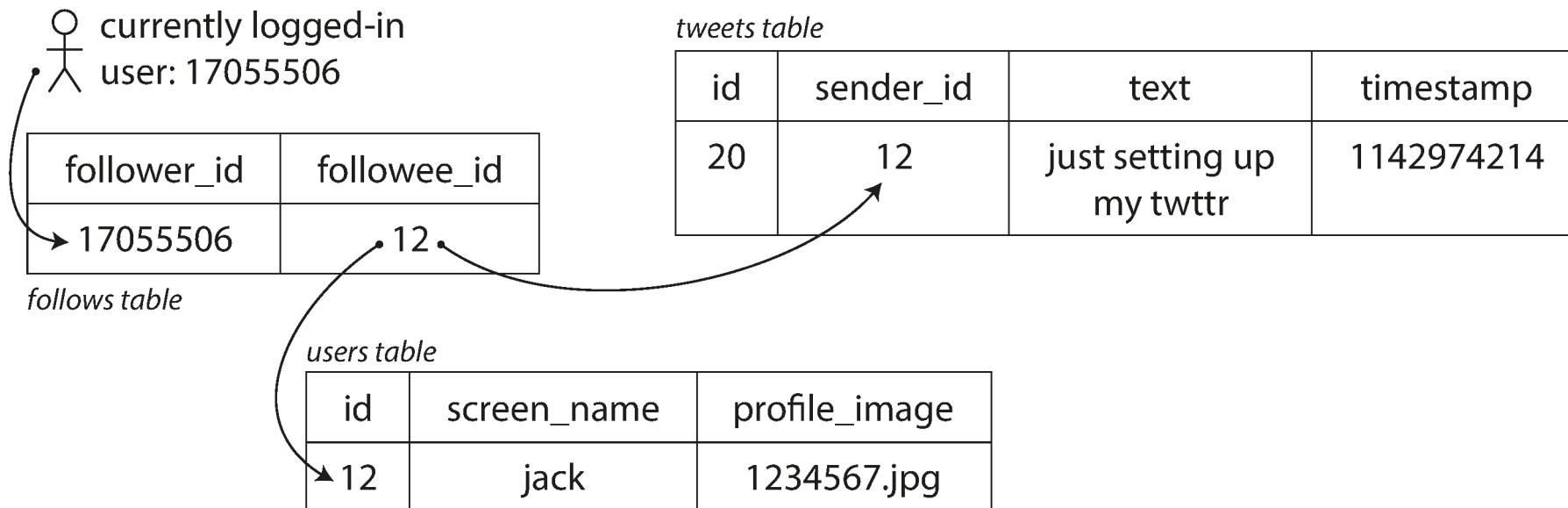

Design Option #2: Timeline Cache

- For each user, maintain the current view (cache) of their timeline
- **Post tweet:** (1) Look up all the people who follows the user and (2) insert the new tweet into each of their timeline
- **View timeline:** Inexpensive; no need to re-compute the timeline

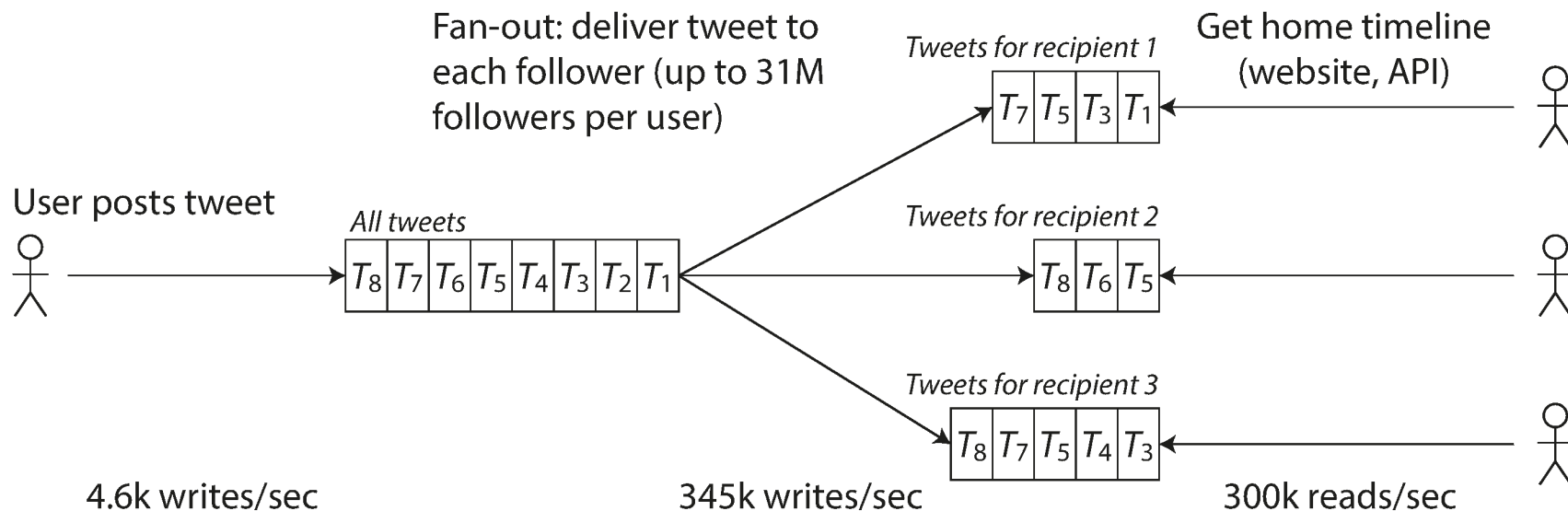

Discussion: Which Option?

- Design Option #1: Reconstruct the timeline at every request
- Design Option #2: Maintain & update a cache of timeline
- **Q. Which option would you prefer for better scalability, and under what assumptions?**
 - **What additional information about the load do you need to make the decision?**

Discussion: Which Option?

- **Design Option #1:** Reconstruct the timeline at every request
 - Used in an older design of Twitter, but difficulty dealing with an increasing number of timeline requests
- **Design Option #2:** Maintain & update a cache of timeline
 - More scalable for timeline requests
 - For post tweet: $4.6\text{k writes/sec} * (\text{average \# followers} \sim 75) = 345\text{k writes/sec}$
 - But what if a user (e.g., celebrity) has a very large number of followers?
- In practice: **Hybrid solution!**
 - Option #2 for most users; Option #1 for users with very high # followers
- **No one solution fits all!** Design decisions for scalability must consider workloads under different scenarios and user interactions.

Describing Performance: Common Metrics

- **Throughput**: Amount of work processed per time period
- **Response time (RT)**: Time between a client's request & response received
 - Average RT: Commonly used, but not very useful (**Q. why not?**)
 - Percentile RT: "1.5s at 95th" means 95% of requests take < 1.5s
 - Median (50th percentile, or p50): How long users typically wait

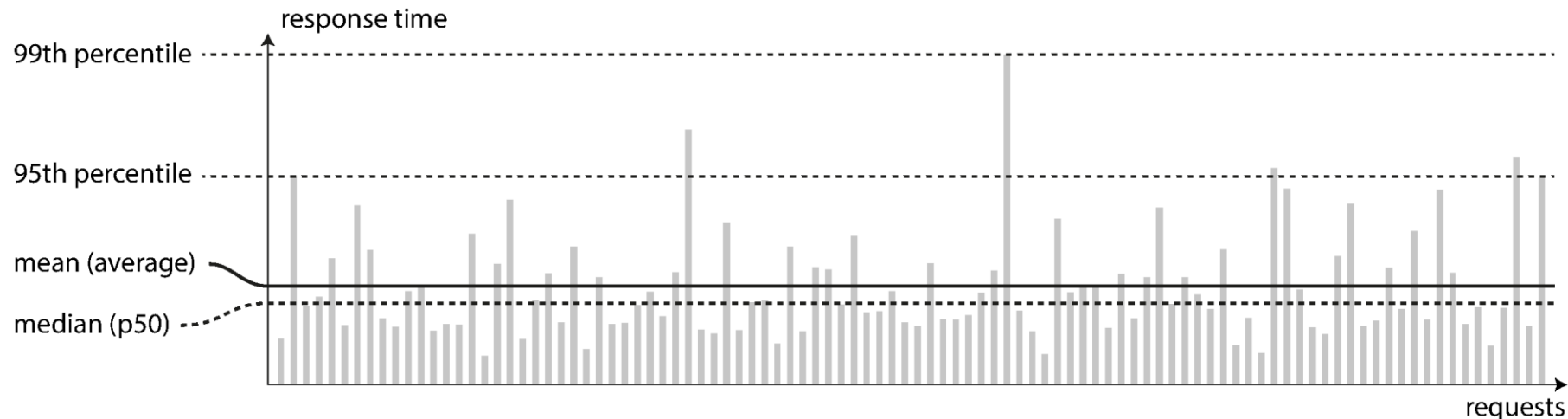

Performance Matters!

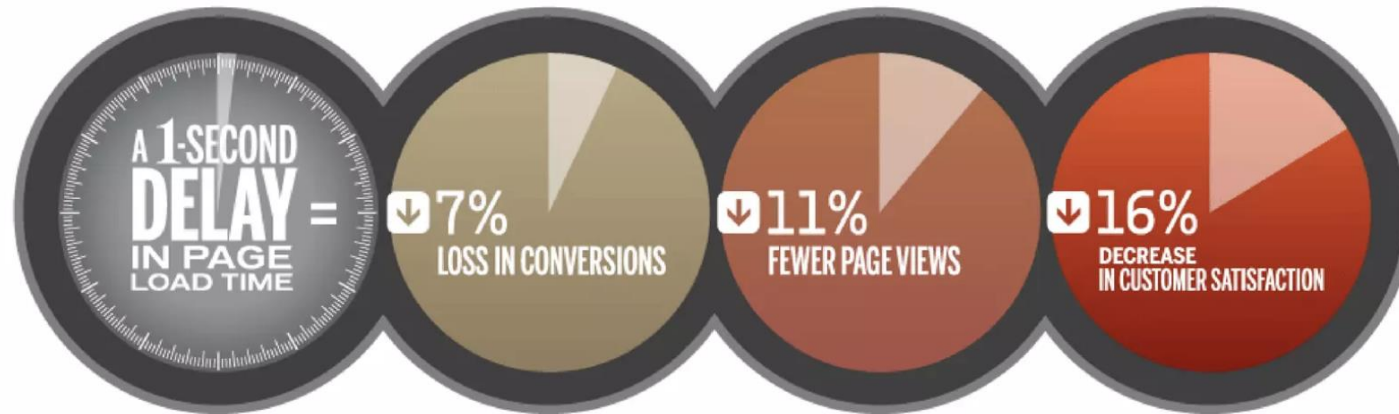

IN DOLLAR TERMS,
this means that if your site typically earns \$100,000 a day, this year
you could lose **\$2.5 MILLION** in sales.
SOURCE: Aberdeen Group

- Performance affects other business metrics, such as revenue, conversions/downloads, user satisfaction/retention, time on site, etc.,

Source: [The Real Cost of Slow Time vs Downtime](#), Tammy Everts (2014)

Design Patterns for Scalability

Common Design Problems for Scalability

- How do we increase capacity to handle additional load? **Vertical & horizontal scaling**
- How do we avoid overloading one part of the system due to increased load? **Load balancing**
- How do we reduce bottleneck in the overall workload? **Caching**

Vertical vs. Horizontal Scaling

- **Problem: How do we increase capacity to handle additional load?**
- **Vertical scaling** (*scaling up*): Get a more powerful machine!
- **Horizontal scaling** (*scaling out*): Distribute the load across multiple machines!

Vertical scaling

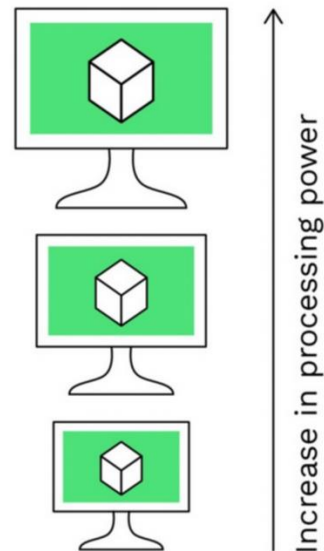

Horizontal scaling

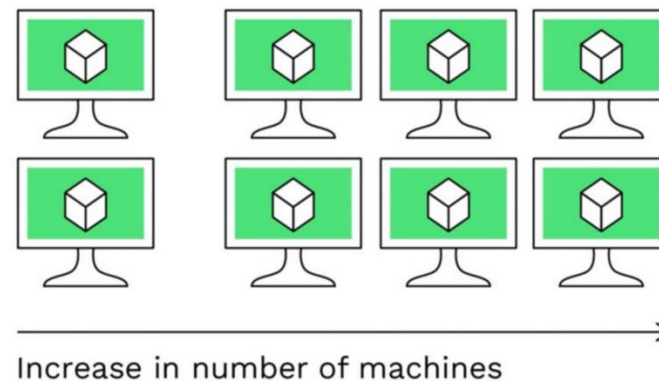

Vertical vs. Horizontal Scaling

- **Problem: How do we increase capacity to handle additional load?**
- **Vertical scaling** (*scaling up*): Get a more powerful machine!
- **Horizontal scaling** (*scaling out*): Distribute the load across multiple machines!
- **Q. What are the benefits & downsides of each approach?**

Vertical vs. Horizontal Scaling

- Problem: H
- Vertical sca
- Horizontal machines!
- Q. What are
 - So does



- additional load?
- machine!
- cross multiple
- roach?
- er choice?

Vertical vs. Horizontal Scaling

- **Problem: How do we increase capacity to handle additional load?**
- **Vertical scaling** (*scaling up*): Get a more powerful machine!
- **Horizontal scaling** (*scaling out*): Distribute the load across multiple machines!
- **Q. What are the benefits & downsides of each approach?**
 - So does this mean horizontal scaling is always the better choice?
- In practice, most systems use a hybrid approach
 - Vertical scaling, where possible, is simpler and more efficient
 - **Example:** [StackExchange Architecture](#)

Distributed Data

Relational vs. Document Model

- **Relational data model:** Schemas, tables & queries (e.g., SQL)

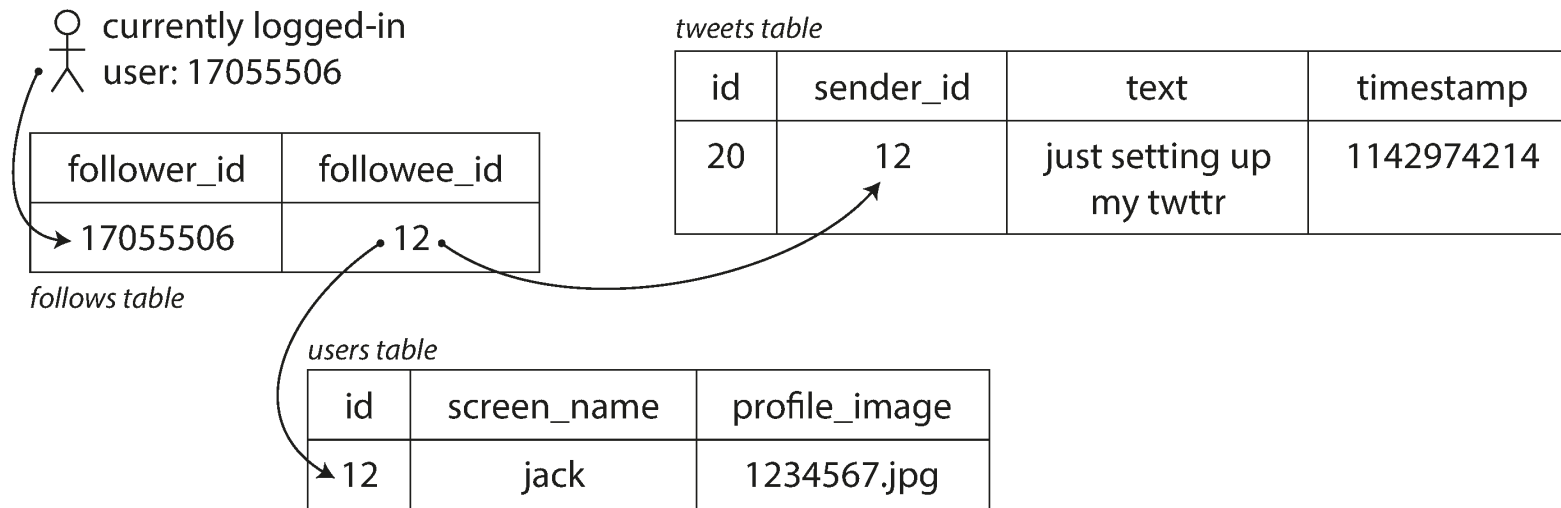

```
SELECT tweets.*, users.* FROM tweets
JOIN users ON tweets.sender_id = users.id
JOIN follows ON follows.followee_id = users.id
WHERE follows.follower_id = current_user
```

Relational vs. Document Model

- **Relational data model:** Schemas, tables & queries
- **Document model:** No fixed schema, semi-structured (e.g., JSON/XML)

```
{
  "id": 2,
  "firstName": "Niels",
  "lastName": "Bohr",
  "address": {
    "streetName": "Flemsevej",
    "streetNumber": "31A",
    "city": "København"
  },
  "emergencyPhoneNumbers": []
},
...
```

**Q. Benefits & drawbacks of each model?
When would you choose one over the other (in relation to scalability)?**

When to use document model?

- Which model to use? **Again, it depends!**
- **One-to-many** relationship between data elements
 - Forms a tree-like structure
 - Data query through indexing operations
 - e.g., positions[0]
- **Data locality**
 - A document (e.g., JSON) object is stored as a continuous string
 - Efficient when the entire object needs to be accessed at once

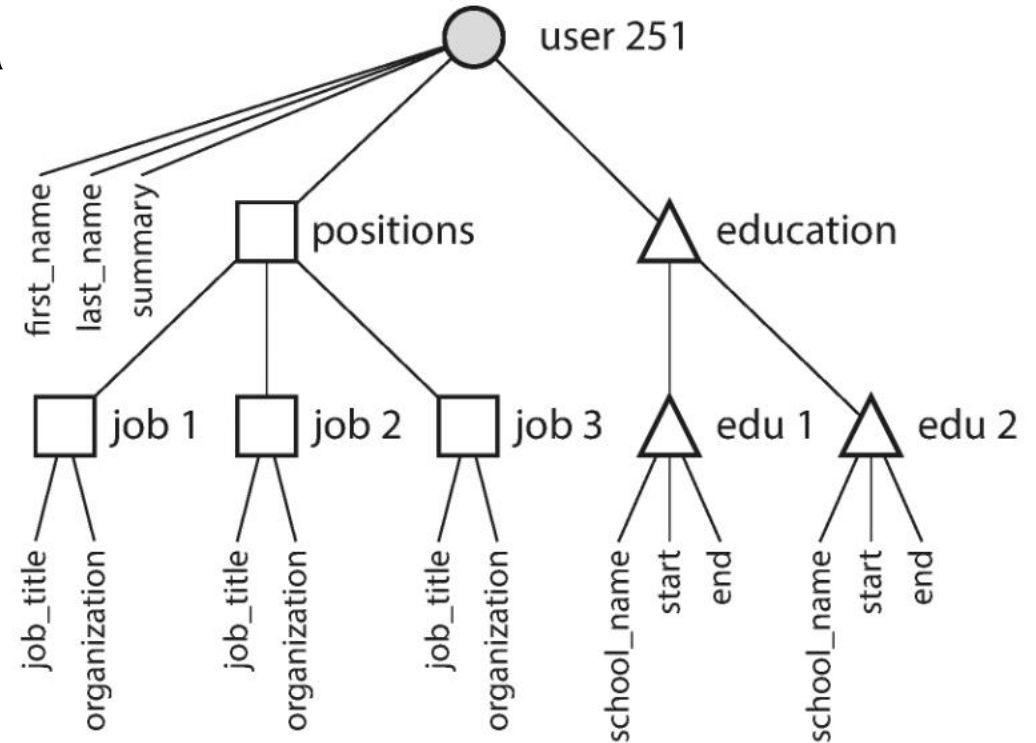

When to use relational model?

- **Many-to-many** relationships between data elements
 - Data query involves relational join
 - Awkward and inefficient in document model
- **Data integrity and transaction guarantees**
 - Schema and integrity constraints enforced
 - **Transaction:** When something goes wrong, roll back to previous state

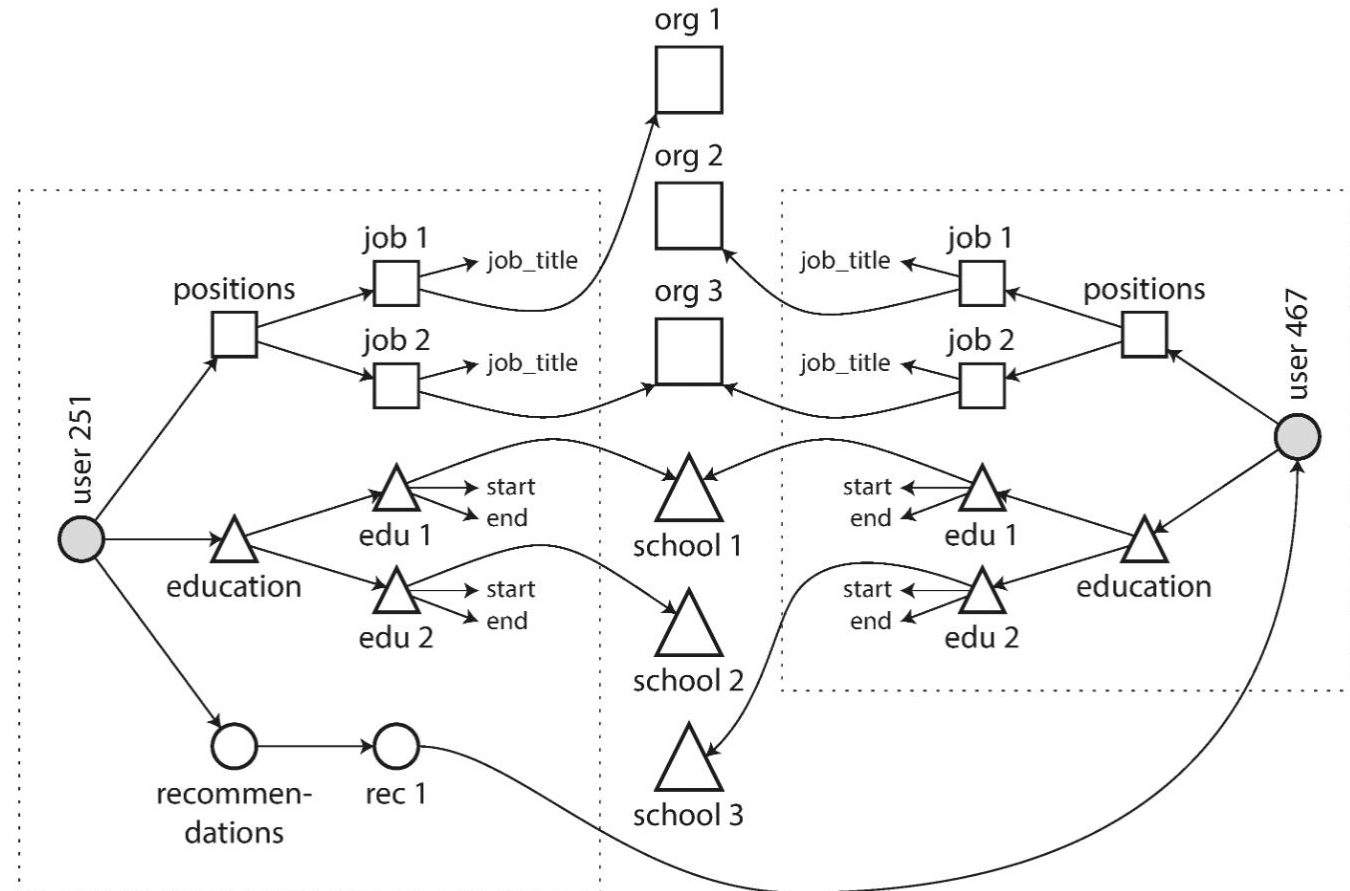

Horizontal Scaling through Distributed Data

- Distribute load across multiple machines
 - Typically involves distributing & storing data across those machines
- Two ways to distribute data: **Replication** and **partitioning**
- Many systems use a hybrid approach that combines both

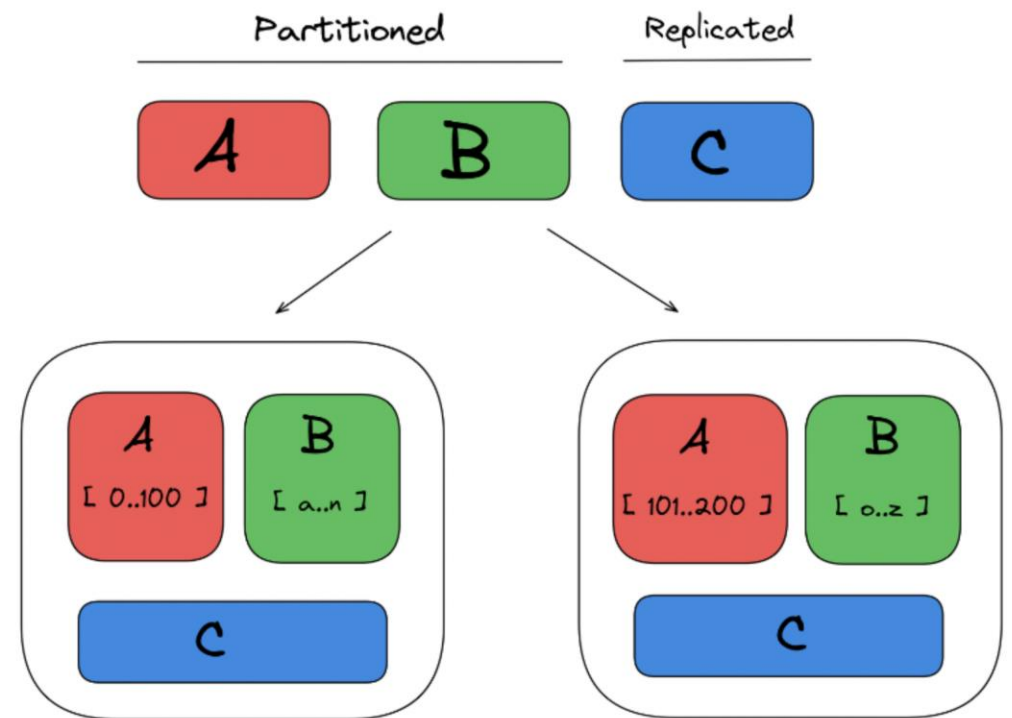

Distributed Data: Replication

- **Replication:** Copy & store data across multiple machines (or *nodes*), possibly in different locations.
 - **Fault-tolerant:** If some nodes become unavailable, data can be access from the remaining nodes
 - **Performance:** Requests can be directed to a node that is physically closer (reduced latency)
 - **Scalability:** Increased load can be handled by adding more nodes with replicated data

Q. This sounds great! What's the catch?

Replication: Challenges

- **Consistency**: If data on one node changes, how do we ensure that all its replicas have the same, consistent data?
 - Clients may read **outdated** data from inconsistent nodes
 - **Node failures**: What if some of the nodes fail before updating its data?
- There are several different approaches to dealing with these challenges
- This is an active area of research (called *distributed systems*); you can take multiple courses on this topic alone
- We will cover one well-known approach: **Leader-follower model**

Leader-Follower Model

- Designate one of the replicas as the **leader**; the rest are **followers**
- Write operations are allowed only on the leader
- When data changes on the leader, send update to every follower

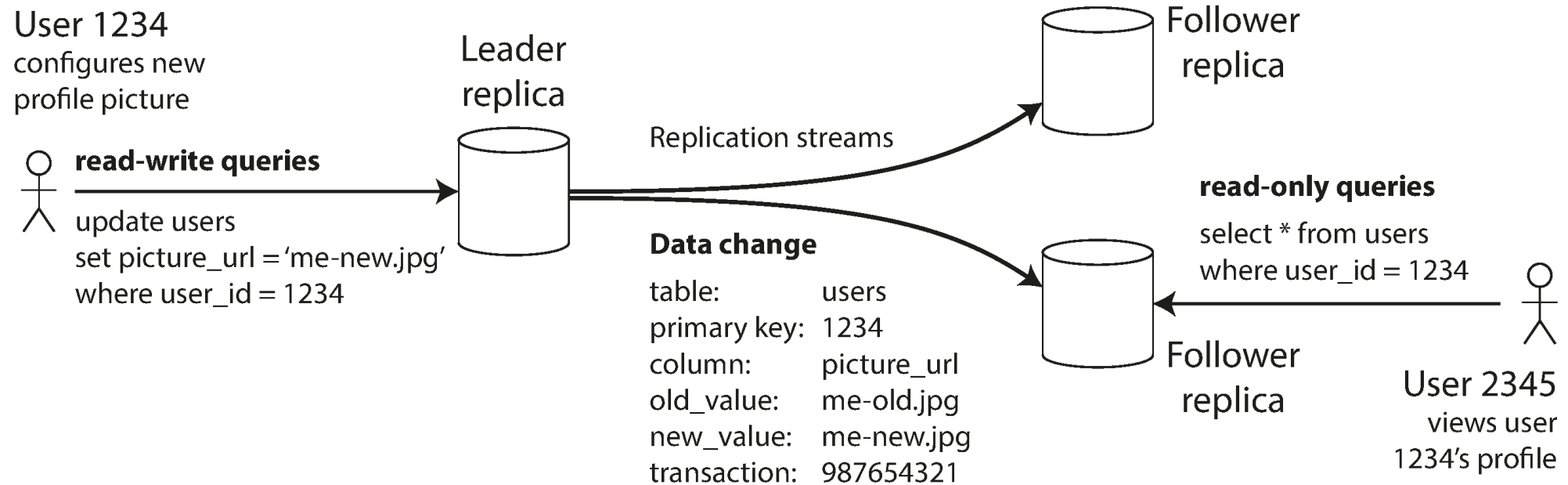

Synchronous vs. Asynchronous Replication

- **Synchronous:** The leader waits until the follower confirms that it has received the update
- **Asynchronous:** The leader sends the update and continues without confirmation

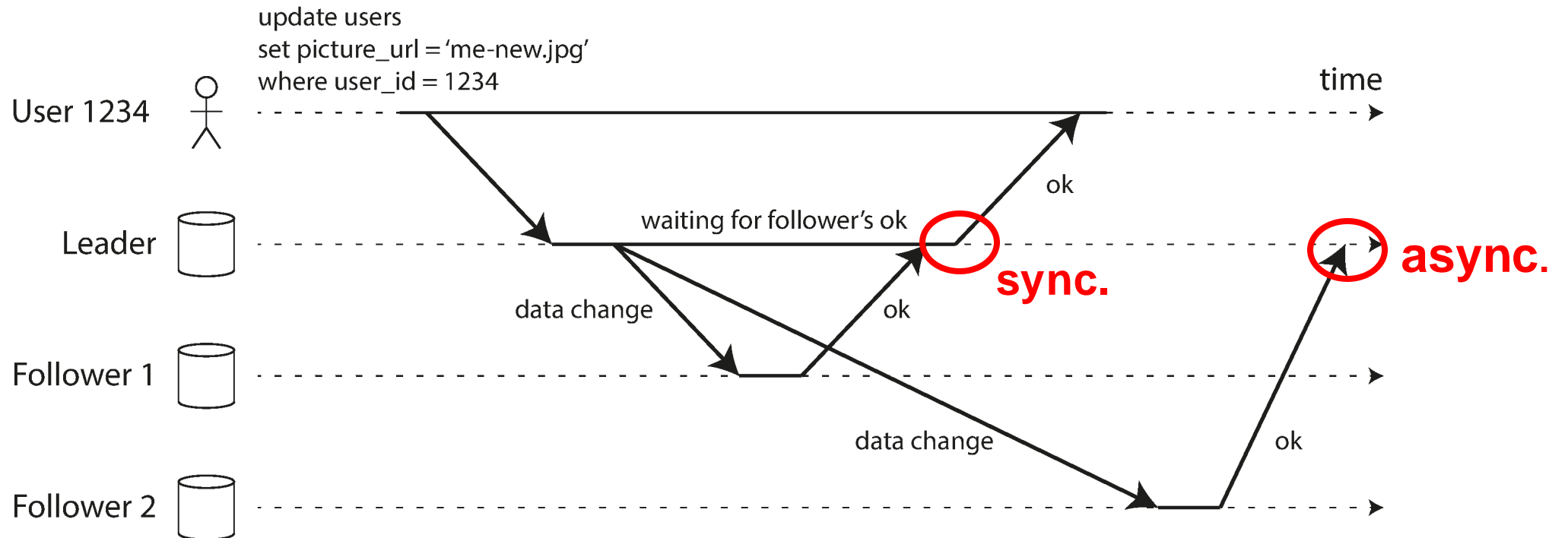

Synchronous vs. Asynchronous Replication

- **Synchronous:** The leader waits until the follower confirms that it has received the update
- **Asynchronous:** The leader sends the update and continues without confirmation
- **Q. What are the benefits & downsides of each design? What types of applications does one approach makes more sense over the other?**

Synchronous vs. Asynchronous Replication

- **Synchronous:** The leader waits until the follower confirms that it has received the update
 - **Pros:** Ensures that followers have updated data. If the leader fails, latest data can still be read from the followers
 - **Cons:** Higher latency for the client; some followers may fail and never return a confirmation
- **Asynchronous:** The leader sends the update and continues without confirmation
 - **Pros:** Higher performance; the leader can continue to process client requests
 - **Cons:** Weaker guarantees on consistency across replicas
- **Hybrid model:** Assign some followers to be synchronous, the others asynchronous

Digression: CAP Theorem

- **Consistency:** Clients always read the latest data
- **Availability:** Services are available for clients to access
- **Partition tolerance:** System continues to operate despite network failures
- **CAP theorem:** Choose two out of three
 - e.g., if a network failure occurs (and system tolerates it), choose consistency or availability
- Demonstrates trade-offs between different qualities of scalable systems
 - But somewhat controversial; some people argue it as being misleading

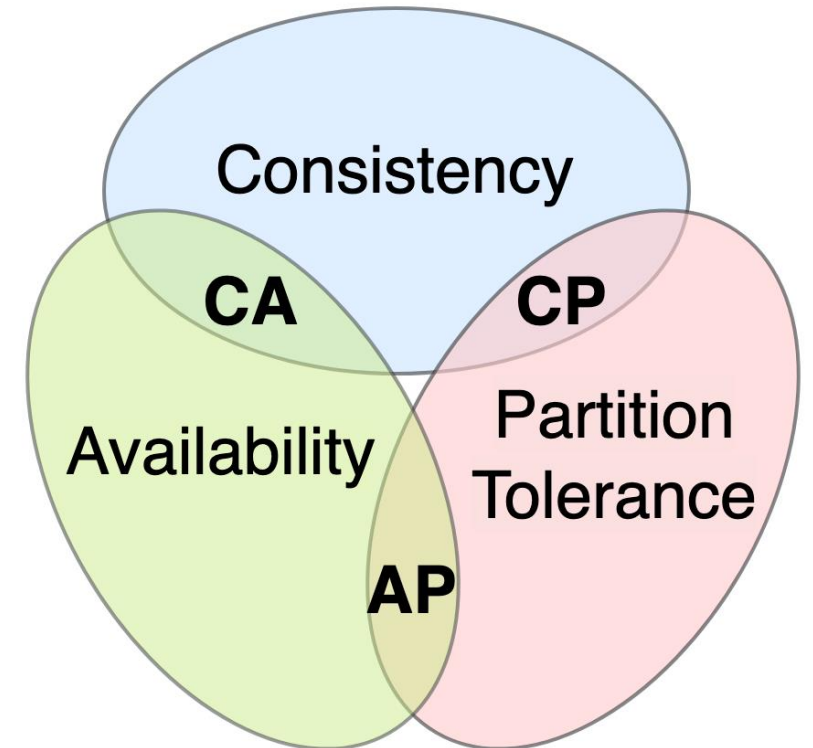

Distributed Data: Partitioning

- **Partitioning** (also called *sharding*): Split the data into smaller, independent units & distribute them across nodes
 - Useful and necessary when one dataset is too large to be fit onto a single node (i.e., replication alone is not sufficient!)
 - Usually combined with replication: Each partition is replicated stored across multiple nodes

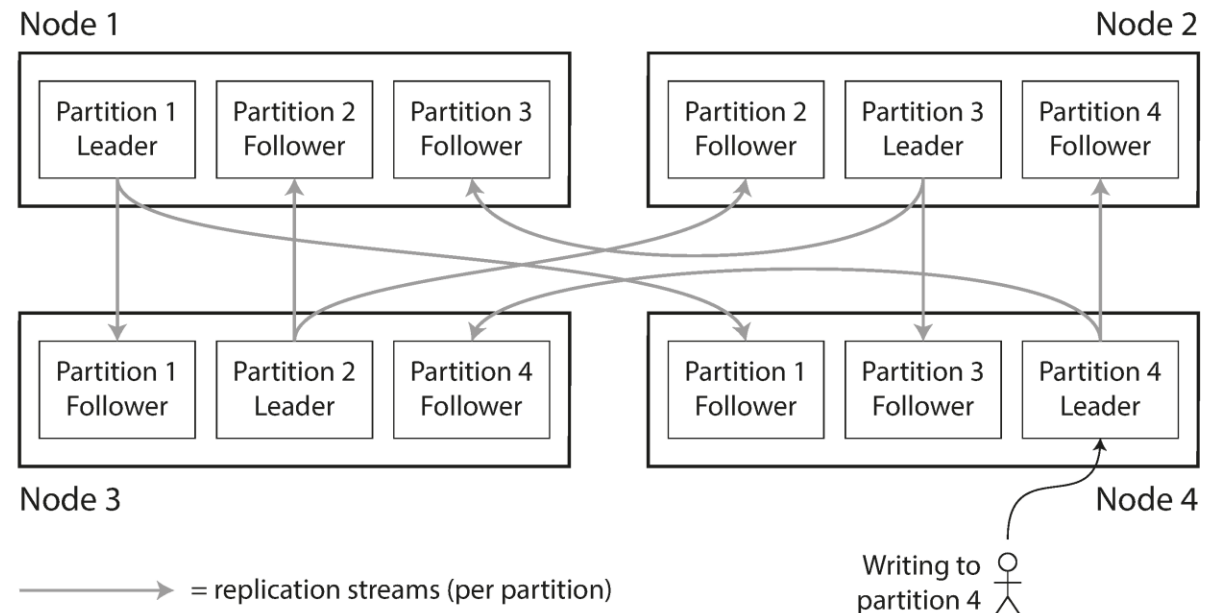

Distributed Data: Partitioning

- **Partitioning** (also called *sharding*): Split the data into smaller, independent units & distribute them across nodes
 - Useful and necessary when one dataset is too large to be fit onto a single node (i.e., replication alone is not sufficient!)
 - Usually combined with replication: Each partition is replicated stored across multiple nodes
- Types of partitioning
 - **Horizontal**: Partition a series of data by rows
 - e.g., Split user IDs into ranges ([A-G], [H-N],...)
 - Partition based on geographical regions, timestamp, logical categories
 - **Vertical**: Partition a series of data by columns
 - e.g., Split user table into (profile info, user images)
 - Partition based on data access frequency, data size, data sensitivity

Prime Big Deal Days

Included with a Prime membership



October 10-11

Twitter is over capacity.

Too many tweets! Please wait a moment and try again.

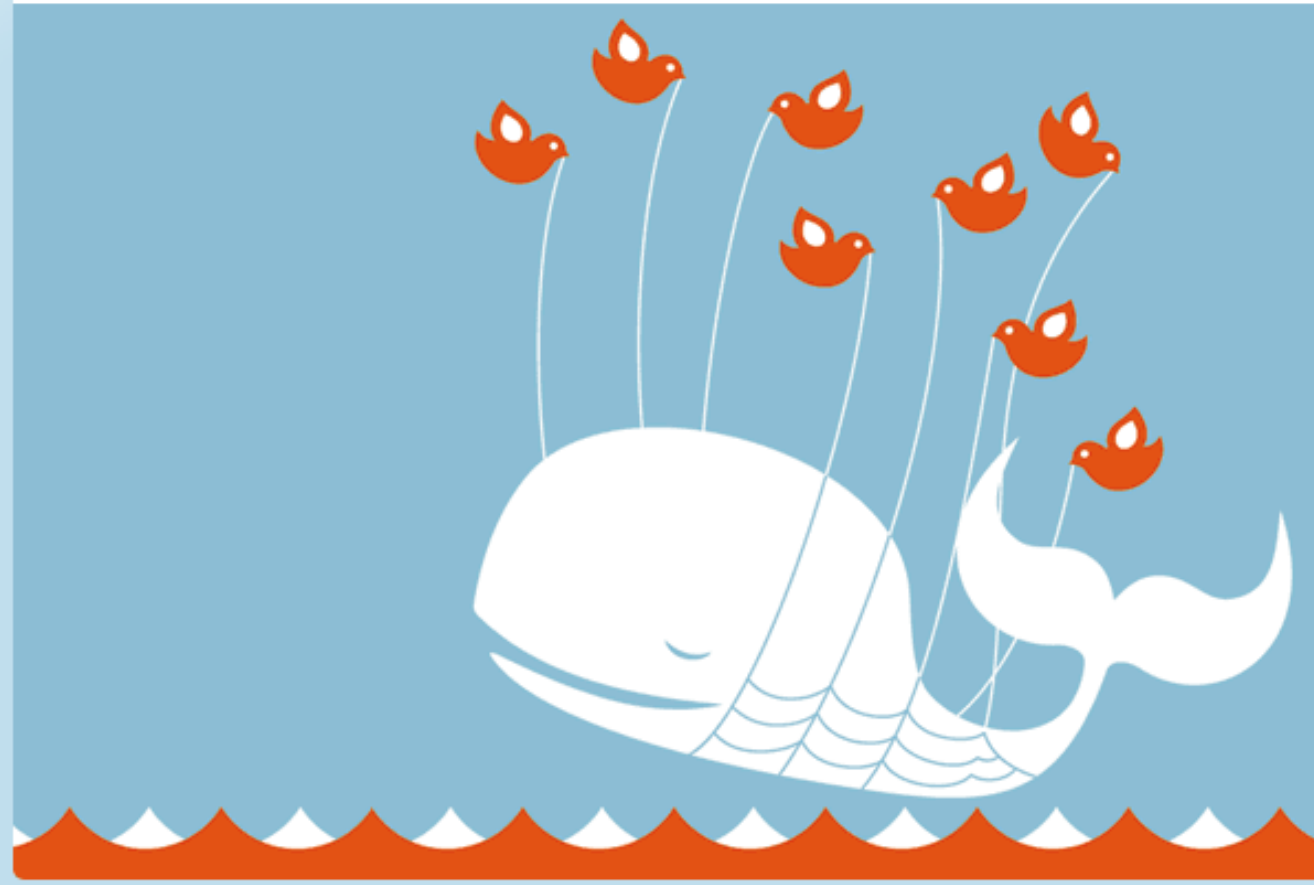

Distributed Data: Partitioning

- **Partitioning** (also called *sharding*): Split the data into smaller, independent units & distribute them across nodes
 - Useful and necessary when one dataset is too large to be fit onto a single node (i.e., replication alone is not sufficient!)
 - Usually combined with replication: Each partition is replicated stored across multiple nodes
- **Other design considerations**
 - How to rebalance partitions (when new data is added over time)
 - How to route client requests to the right partition (e.g., Zookeeper)
 - More details in the assigned reading (Chapter 6, Kleppman)

Summary: Vertical vs. Horizontal Scaling

- Vertical and horizontal scaling are two major ways of adding capacity to a system
- Horizontal scaling typically involves distributing data across multiple nodes, to allow load to be divided among the machines
- Replication and partitioning are two common ways of distributing data
- Despite multiple benefits (performance, scalability, fault-tolerance), distributing data introduces new challenges into the design task
- Start with vertical scaling if possible! It's simpler and more efficient

Exercise: Designing Movie Streaming Service

- Sketch a design of a movie streaming service (e.g., Netflix), focusing on two operations: **Browsing recommended movies** and **playing a movie**
- **Questions to discuss:**
 - What data do we need store for the operations?
 - What type of data model (relation vs. document) for which data?
 - What type of scaling (vertical, horizontal, or both) do we apply?
 - How do we distribute data (replication, partitioning, or both)?
 - If replication is used, synchronous vs. asynchronous replication?

Load Balancing

Common Design Problems for Scalability

- How do we increase capacity to handle additional load? Vertical & horizontal scaling
- **How do we avoid overloading one part of the system due to increased load? Load balancing**
- How do we reduce bottleneck in the overall workload? Caching

Load Balancing (LB)

- The process of distributing workload across multiple machines, to avoid overloading parts of the system

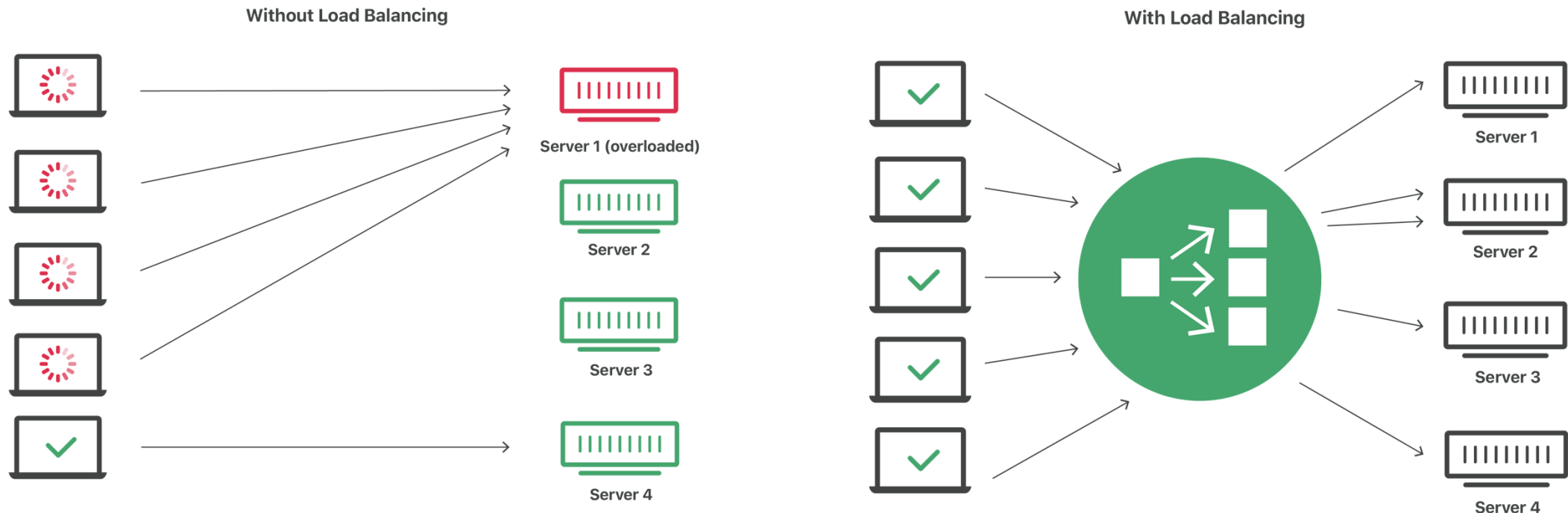

Image source: <https://www.cloudflare.com/learning/performance/what-is-load-balancing/>

Load Balancing (LB)

- The process of distributing workload across multiple machines, to avoid overloading parts of the system
- Benefits:
 - **Scalability**: Handle high workload by distributing them evenly
 - **Availability**: Run maintenance & upgrades without application downtime
 - **Performance**: Redirect client requests to a geographically closer node
 - **Security**: Monitor, identify, and block problematic traffic (e.g., denial-of-service attacks)

Types of LB Algorithms

- **Static LB methods**

- Use fixed rules that are independent of the current state of the nodes
- Easy to set up & can be made very efficient, but only if the actual workload matches the expected pattern

- **Dynamic LB methods**

- Dynamically decide how to distribute traffic based on the current state
- **State information:** For each node, amount of utilization, number of outstanding requests, average response time, etc.,
- More complex to design & deploy, but also more robust to varying workloads

Static LB Algorithms

- Round-robin
 - Assign client requests to the nodes in the round-robin fashion
 - **Q. Possible downside?**

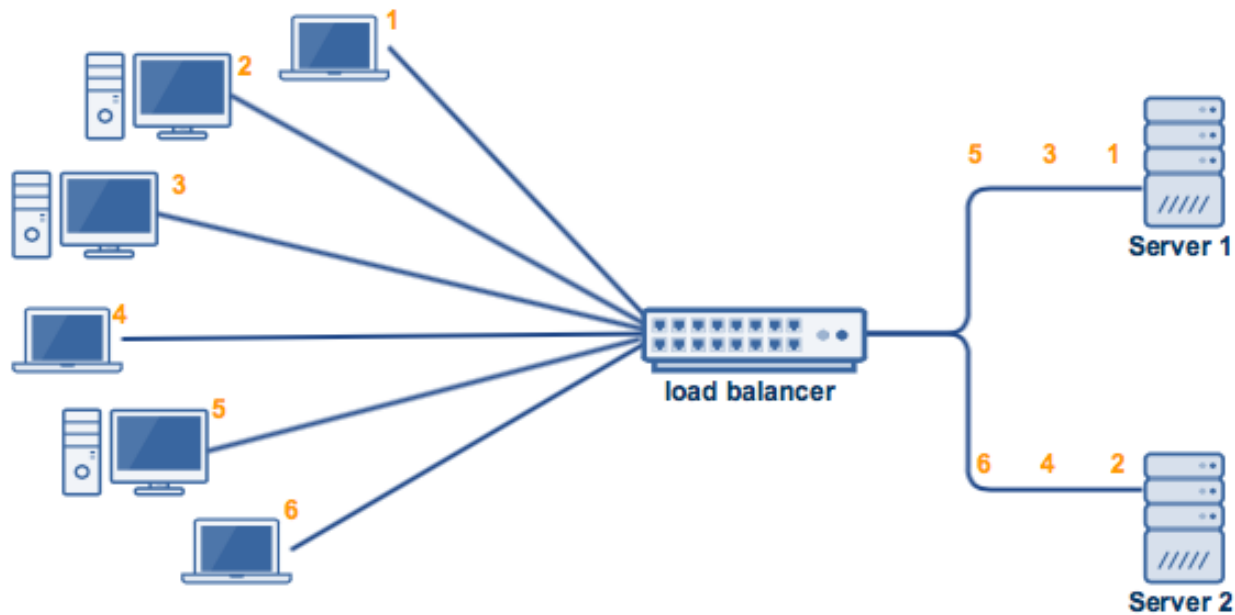

Static LB Algorithms

- **Round-robin**

- Assign client requests to the nodes in the round-robin fashion
- **Downside:** Disregards the capacity (e.g., processing power) differences between the nodes

- **Weighted round-robin**

- Round-robin, but each node is also weighted based on its capacity; nodes receive amount of load in proportion to their weights

- **IP hash method**

- Compute a hash of the client's IP address & map requests to the node with the corresponding hash
- Useful for ensuring consistent connection between a specific pair of client and machine

Dynamic LB Algorithms

- **Least connection**
 - Check the number of connections to the nodes & assign task to the least busy nodes (can also be weighted based on their capacity)
- **Average response time**
 - Monitor the average response time (RT) for each node & assign task to the ones with the fastest RT
- **Resource-based**
 - Measure available CPU & memory on each node & assign task to the ones with the most available resources
- A hybrid of one or more of these

([Animation of LB methods](#))

Exercise: Which LB algorithm?

- For each of the following applications:
 - What are unique characteristics of the client request/load pattern?
 - Which LB to use: Round-robin, IP hash, or least connection?
1. News media site (e.g., NYTimes)
 2. Video streaming app (Netflix)
 3. Social media app (Tiktok)

Caching

Common Design Problems for Scalability

- How do we increase capacity to handle additional load? Vertical & horizontal scaling
- How do we avoid overloading one part of the system due to increased load? Load balancing
- **How do we reduce bottleneck in the overall workload? Caching**

Caching

- Store and serve a subset of data in a special storage area (e.g., RAM) that enables faster access
- Improve application performance & reduce the load on the backend
- Can be applied at different layers and locations within a system: Client-side, network, server-side, database, hardware, etc.,

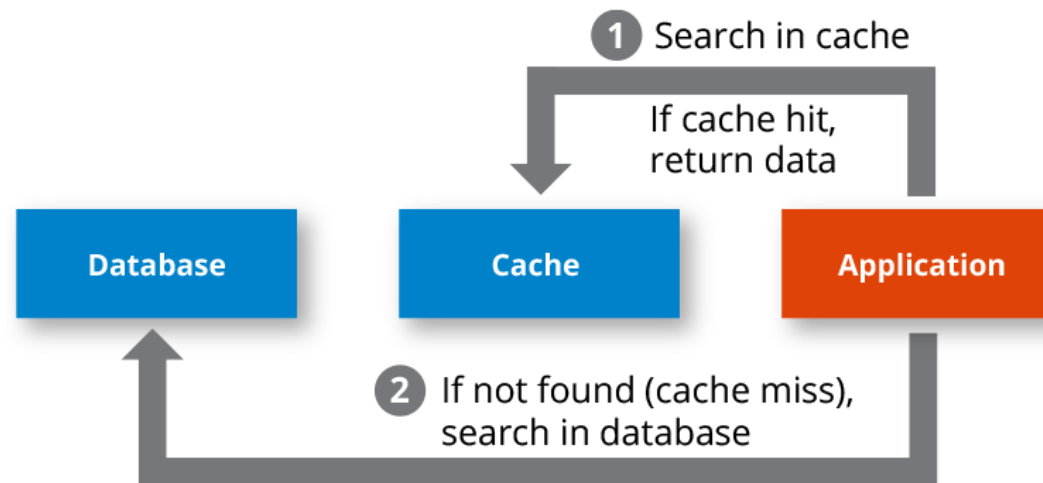

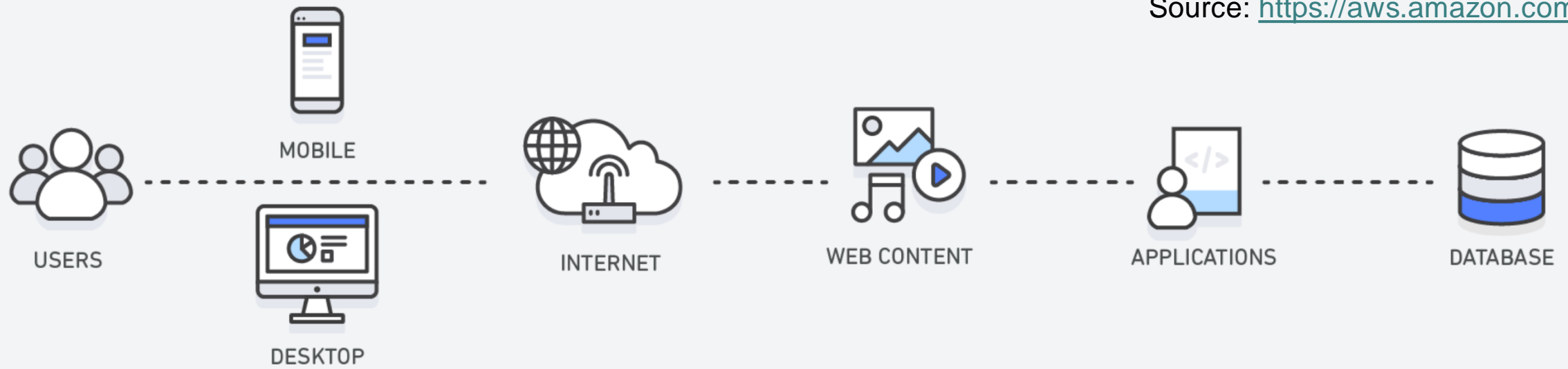

Layer	Client-Side	DNS	Web	App	Database
Use Case	Accelerate retrieval of web content from websites (browser or device)	Domain to IP Resolution	Accelerate retrieval of web content from web/app servers. Manage Web Sessions (server side)	Accelerate application performance and data access	Reduce latency associated with database query requests
Technologies	HTTP Cache Headers, Browsers	DNS Servers	HTTP Cache Headers, CDNs, Reverse Proxies, Web Accelerators, Key/Value Stores	Key/Value data stores, Local caches	Database buffers, Key/Value data stores
Solutions	Browser Specific	Amazon Route 53	Amazon CloudFront , ElastiCache for Redis , ElastiCache for Memcached , Partner Solutions	Application Frameworks, ElastiCache for Redis , ElastiCache for Memcached , Partner Solutions	ElastiCache for Redis , ElastiCache for Memcached

Application-layer Cache

- **Design decision:** Which data do we serve through cache?
- Monitor & identify bottleneck in the workload
- **Determine:** What are some frequently requested or displayed data?

Prime Big Deal Days

Included with a Prime membership



October 10-11

Application-layer Cache

- **Design decision:** Which data do we serve through cache?
- Monitor & identify bottleneck in the workload
- Determine: What are some frequently requested or displayed data?
- **Example: E-commerce site**
 - **Site-wide data:** Top selling products, promotions, pre-rendered HTML (for home page)
 - **User-specific data:** Recommended products, shopping cart status, recent order history
 - Computations based inventory analysis: Stock availability, price trends
- **Benefit:** Avoid redoing computation (e.g., database queries) and reduce response time

Key-Value Store

- Mapping from a key value (e.g., hash of a request) to a data object
- Simple structure (recall: [document data model](#)) & fast lookup; used to serve frequently accessed data
- Typically stored in-memory to optimize access time (e.g., Redis, memcached)

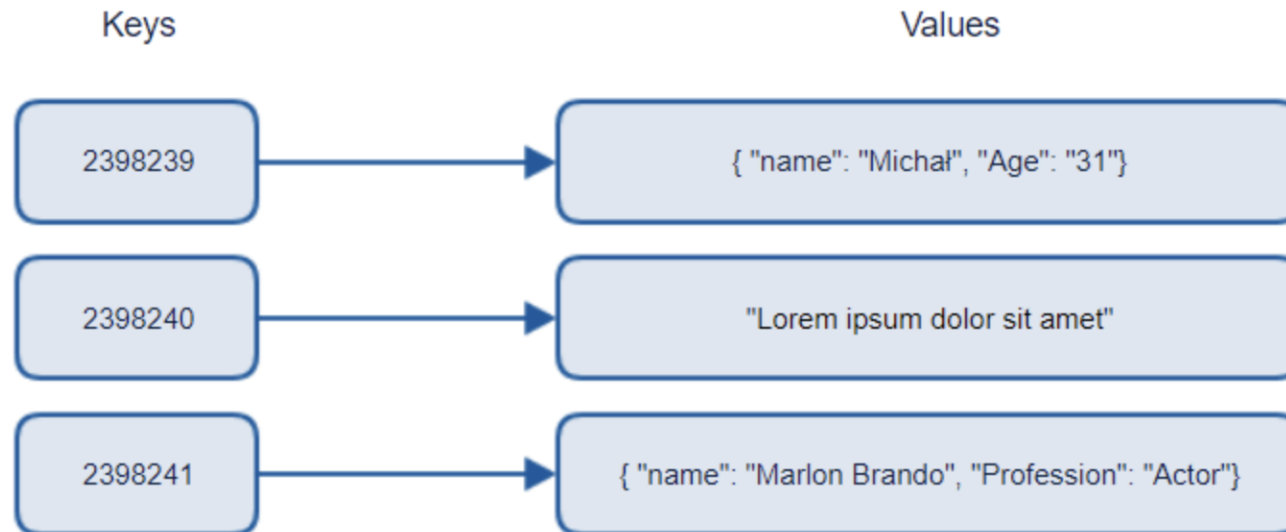

Key-Value Store

- Mapping from a key value (e.g., hash of a request) to a data object
- Simple structure (recall: [document data model](#)) & fast lookup; used to serve frequently accessed data
- Typically stored in-memory to optimize access time (e.g., Redis, memcached)

How Redis is typically used

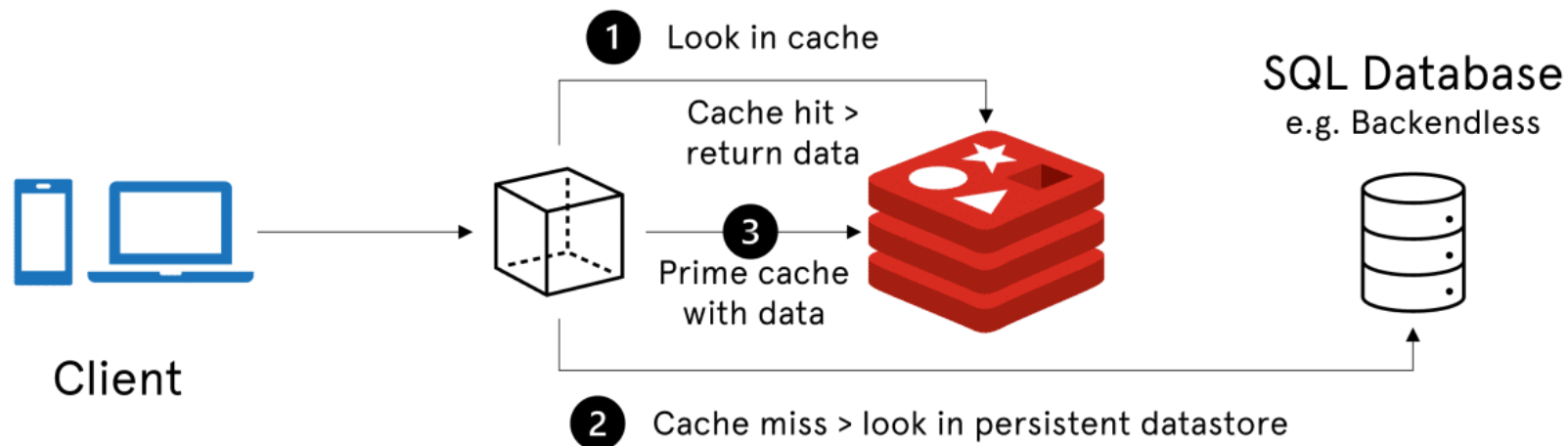

Content Delivery Network (CDN)

- A set of network nodes distributed across geographical locations
- A third-party service that allows an application to deliver a cache of data (e.g., videos, webpages, images, etc.,) to its users
- Application uploads data to be served by a CDN provider
- The provider handles delivery of content to customers from nearby nodes

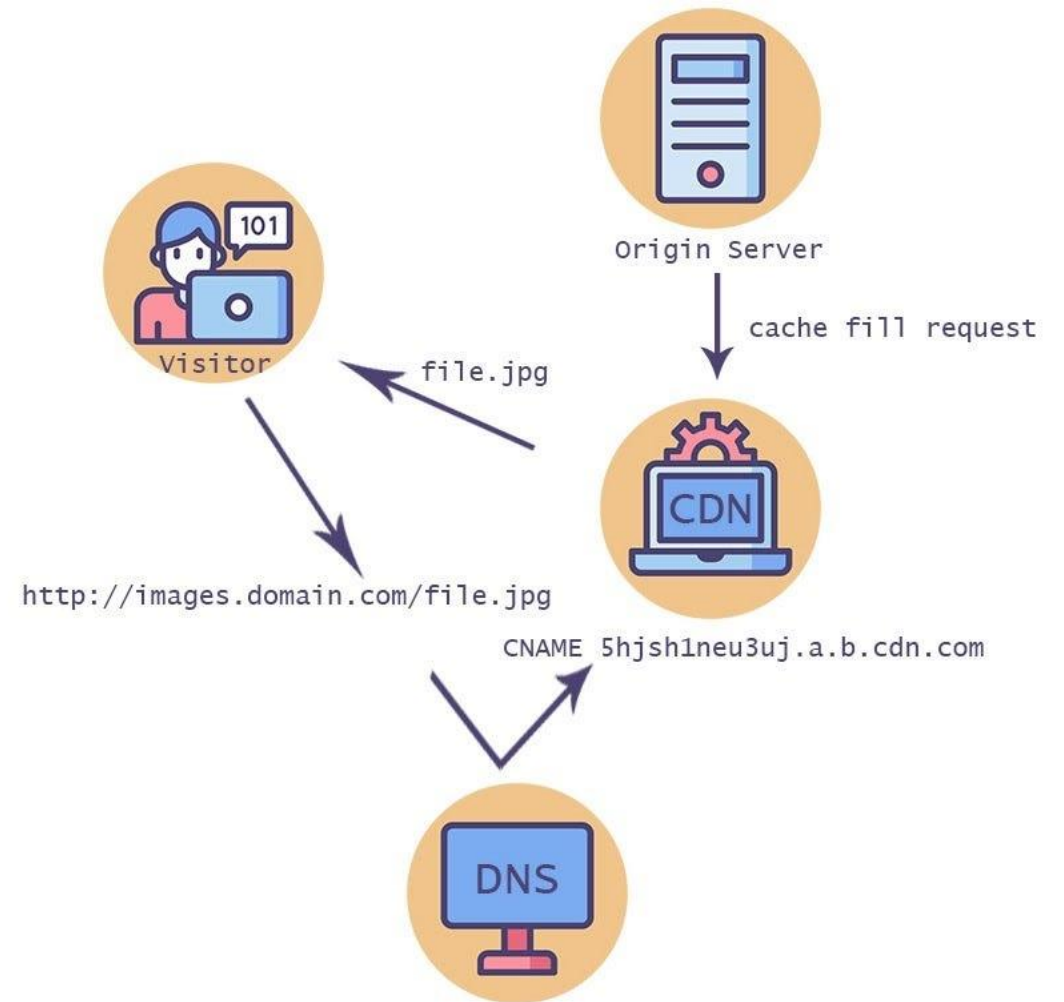

Source: [How the Cloud and CDN Architecture Works for Netflix](#)

Content Delivery Network (CDN)

- **Benefits**

- Improves performance and scalability, without need to build own infrastructure
- Global reach; improved search engine rankings

- **Drawbacks**

- Costly (> \$0.10 per GB)
- Data stored on third-party nodes; potential privacy & security issues
- Dependency on another network; additional point of failure

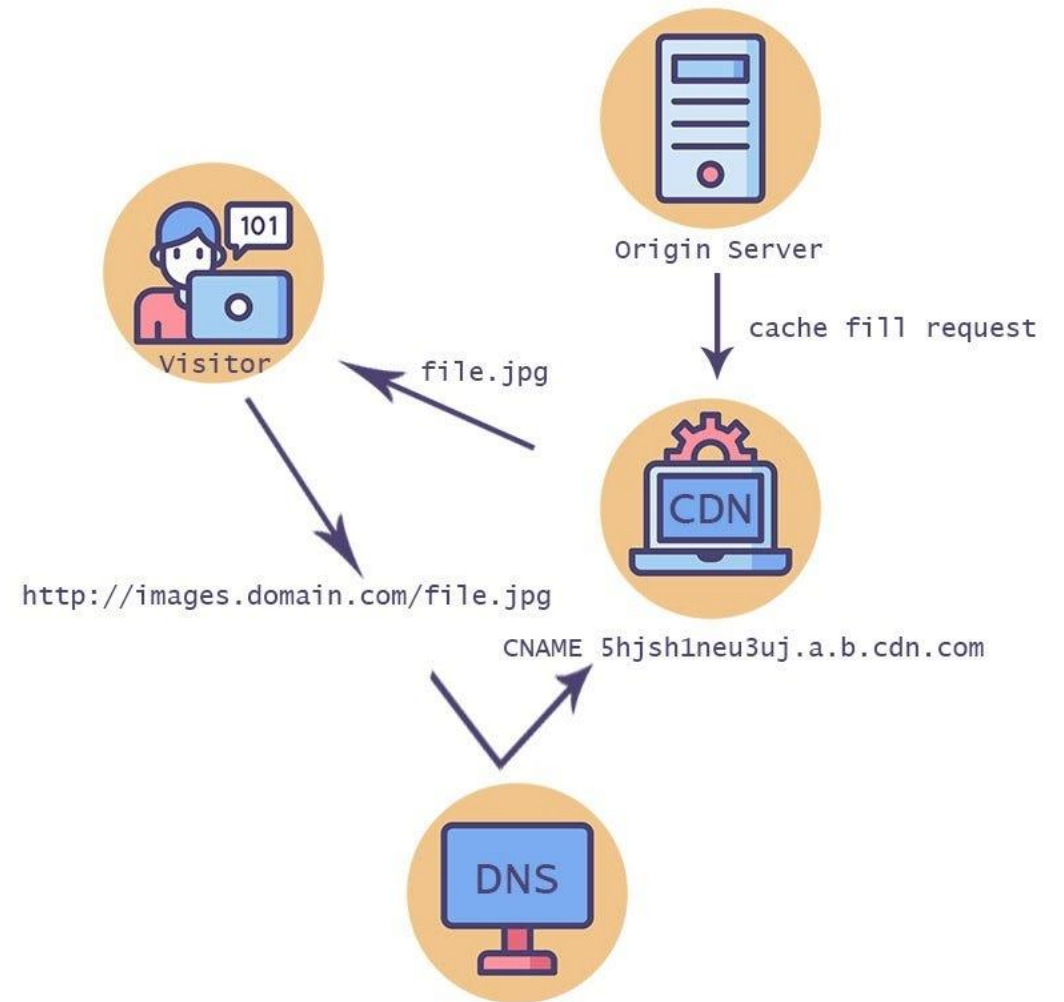

Source: [How the Cloud and CDN Architecture Works for Netflix](#)

Major Internet outage along East Coast causes large parts of the Web to crash – again



By [Timothy Bella](#)

July 22, 2021 at 2:02 p.m. EDT



“...the websites of UPS, USAA, Home Depot, HBO Max and Costco were also among those affected. The websites of British Airways, GoDaddy, Fidelity, Vanguard and AT&T were among those loading slowly.

The cause of the outage, the latest major Internet outage this summer, was linked to Akamai Technologies, the global content delivery network based in Cambridge, Mass.”

Exercise: Designing Movie Streaming Service

- Sketch a design of a movie streaming service (e.g., Netflix), focusing on two operations: **Browsing recommended movies** and **playing a movie**
- **Questions to discuss:**
 - What data do we need store for the operations?
 - What type of data model (relation vs. document) for which data?
 - What type of scaling (vertical, horizontal, or both) do we apply?
 - How do we distribute data (replication, partitioning, or both)?
 - If replication is used, synchronous vs. asynchronous replication?
 - **Which client requests/results/data do we cache?**

Summary: Load Balancing & Caching

- **Load balancing:** Avoid overloading by distributing workload across nodes
- **Caching:** Serve frequently accessed data from a special storage for faster delivery
- Essential part of most modern large-scale systems!
- You probably won't need to (and shouldn't) implement your own LB or caching solutions; many web/DB frameworks support these features
- But application-specific decisions about what data to cache & where to place load balancer are important!

Microservices & Scalability

Microservice Architecture

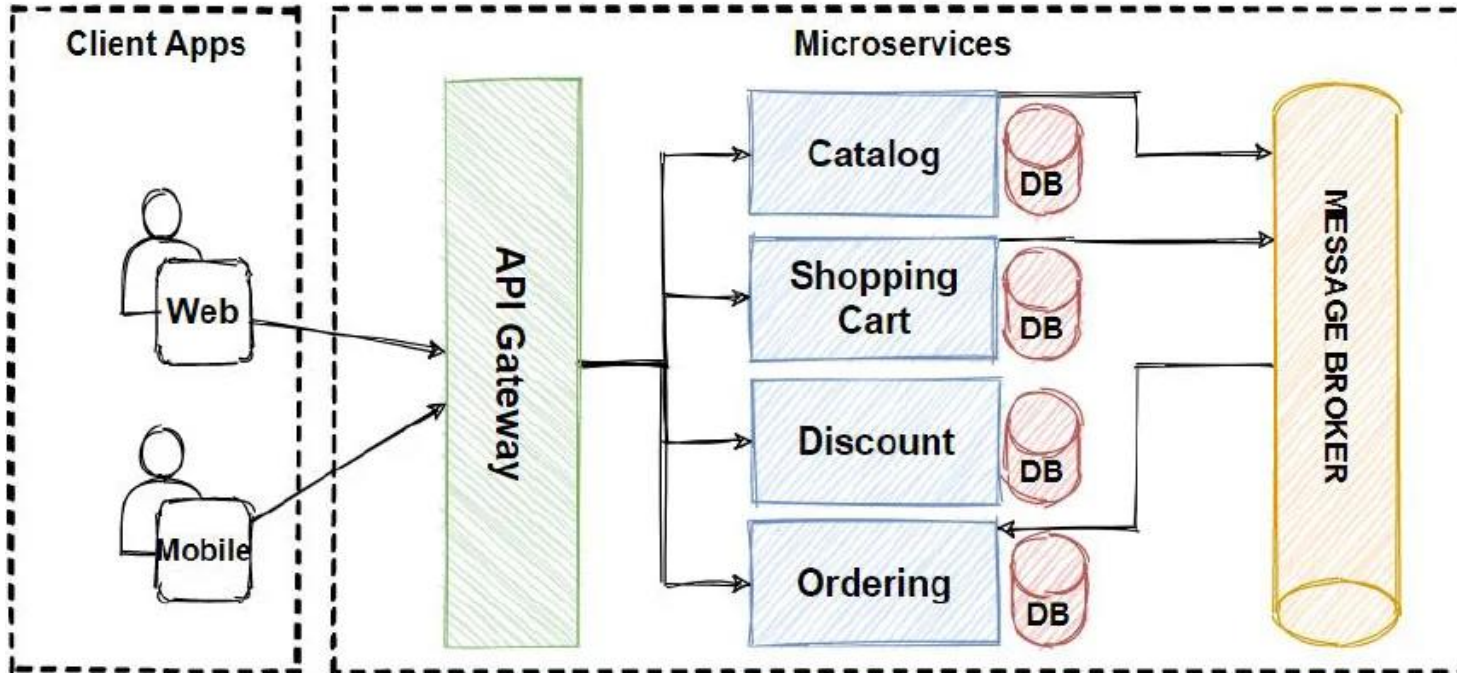

- Decompose system into multiple, deployable units of services, typically developed by independent teams
- User requests are routed to the appropriate service
- Services communicate directly or through a message broker

Microservice Architecture

MONOLITHIC ARCHITECTURE

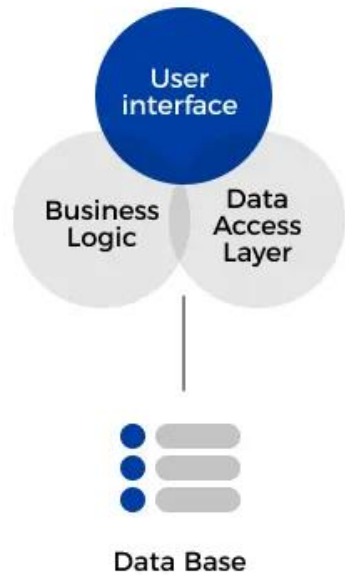

MICROSERVICE ARCHITECTURE

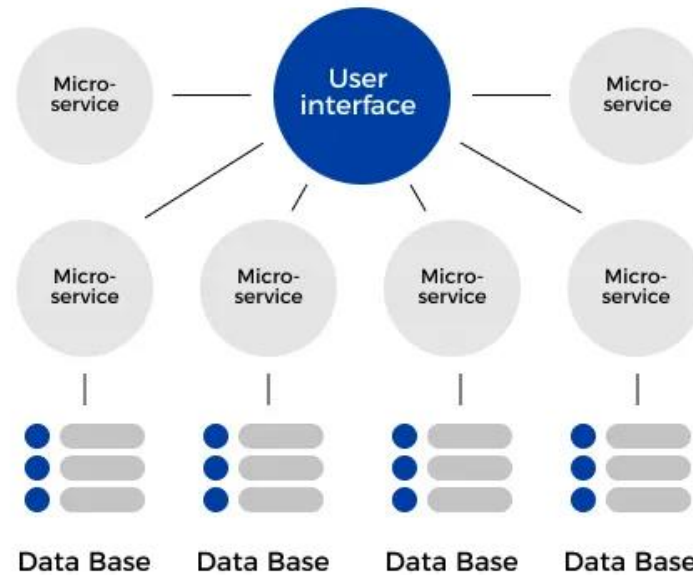

- Q. What are the benefits of a microservice architecture **with respect to scalability**?
- Easier to scale a specific service(s) instead of the entire system

Recall: “Monolith First”

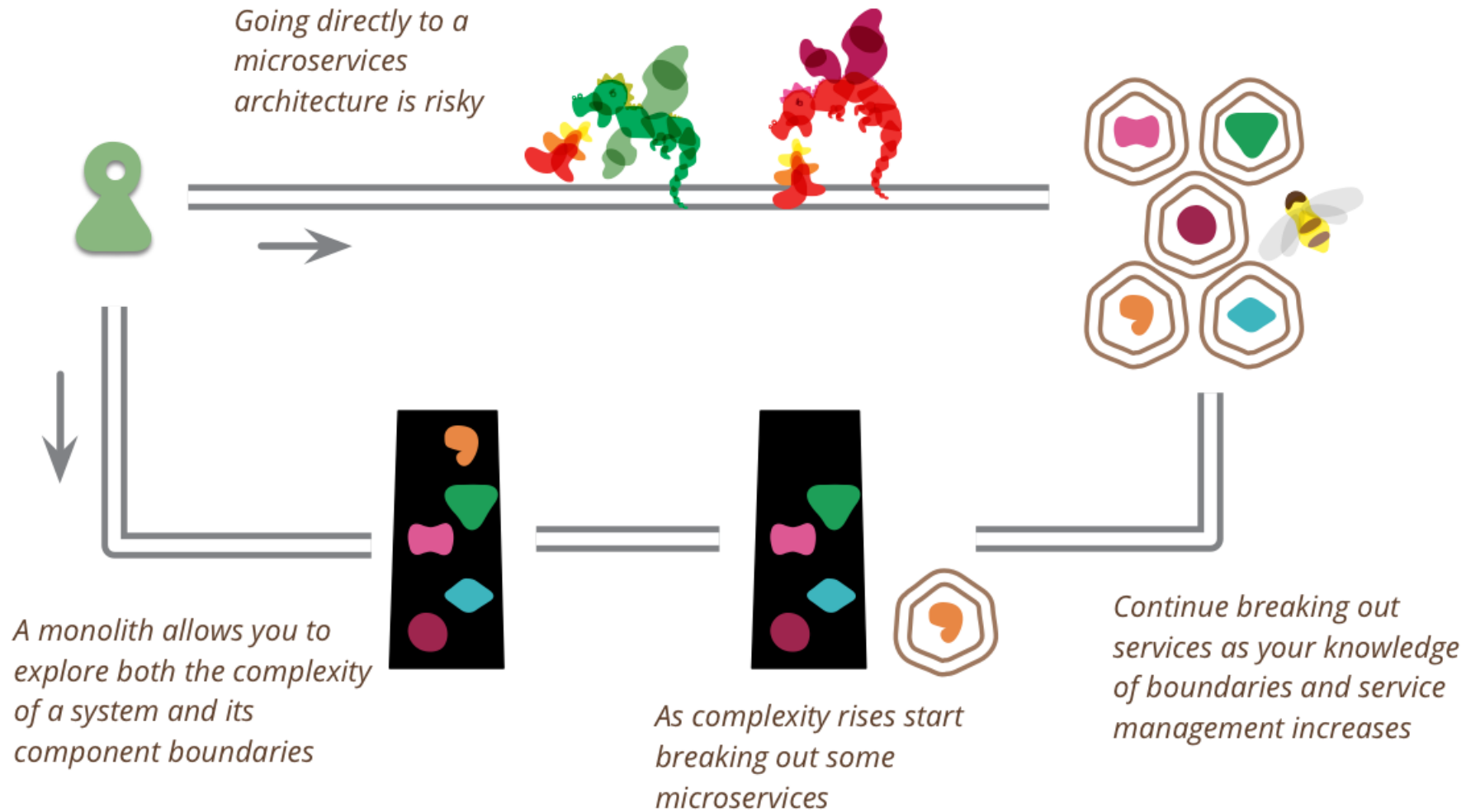

<https://martinfowler.com/bliki/MonolithFirst.html#footnote-typical-monolith>

Design for Scalability: Closing Thoughts

- No generic, one-size-fits-all scalable design (“magic scaling” sauce).
- Many factors to consider: Volume of reads & writes, complexity of data to store, response time requirements, access patterns, or some mix of these
 - Handling 100,000 requests per second, each 1 kB in size vs. 3 requests per minute, each 2 GB in size – same data throughput, but very different design!
- An architecture that scales well for a particular application is built around assumptions about load patterns (e.g., which operations will be common and which will be rare, which data will be frequently accessed, etc.,)
 - If those assumptions turn out to be wrong, the engineering effort for scaling is at best wasted, and at worst counterproductive.
- In an early-stage startup or an unproven product, it’s more important to iterate quickly on product than to scale to some hypothetical future load!

Summary

- Exit ticket!